



# ALFA BITS

*Published by the Alfa Romeo Owners of Oregon*

Alfa Bits

OCTOBER 2015



McGirr Astoria tour  
Photo George Kraus

## A NOTE FROM THE EDITOR

At this month's October meeting I will be presenting a slide show chronicling my 14 month restoration of my 1060 Giulietta Spider Veloce. See [page 7](#) for details. Please show your support of AROO by attending the monthly meetings.

## ALWAYS IN NEED FOR CONTENT

I encourage any and all submissions of either articles or photos for future issues. It's your newsletter, and it will greatly improve with your participation. Submissions are due by the first Wednesday of each month. I will try to publish the *Alfa Bits* one week before the general meeting which is the third Wednesday of each month.

Cheers, *George Kraus* Editor.

**ALFA BITS** is the official newsletter of the Alfa Romeo Owners of Oregon. It is published 10 or 11 times per year in PDF format and is downloadable from the club's website, [www.alfclub.org](http://www.alfclub.org).

We welcome submissions of topical editorial material, and non-commercial buy-sell-trade Alfa-related ads are free for members. Contact [the editor](#) for details, or better yet, just send your ad and we'll let you know if there's a problem. We also welcome paid advertising. Contact Advertising Manager [George Kraus](#) for details.



## About the Club.



## The Board of Directors

### CONTENTS

<a href="#">President's Column, "Driver's Seat"</a>	3
<a href="#">Club Business</a>	4
<a href="#">AROO Needs You</a>	6
<a href="#">The Fall Tour to Astoria</a>	8
<a href="#">The Workshop</a>	9
<a href="#">Activity Calendar</a>	12
<a href="#">NW Classic Rally Needs You</a>	13
<a href="#">NW Classic Rally Sponsors</a>	14
<a href="#">Volunteer Dinner</a>	19
<a href="#">Holiday Party</a>	20
<a href="#">President's Tour</a>	21
<a href="#">Track Day</a>	22
<a href="#">The Back Seat</a>	23

### ADVERTISER INDEX

<a href="#">Sports Car Shop Restorations</a>	5
<a href="#">Sports Car Market</a>	10
<a href="#">Cindy Banzer PDX Properties</a>	11
<a href="#">Nasko's Imports</a>	11
<a href="#">Hagerty Collector Car Insurance</a>	15
<a href="#">Arrow Mechanical Company</a>	15
<a href="#">Columbia Roofing &amp; Sheet Metal</a>	16
<a href="#">Cascade Investment Advisors</a>	16
<a href="#">Sidedraught City</a>	17
<a href="#">PMX Custom Alternators &amp; Starters</a>	17
<a href="#">Guy's Interior Restorations</a>	17



## **AROO NEEDS YOU!**

By Roger Dilts, President

Whether you've been in the Alfa Romeo Owners of Oregon for one, ten, twenty, or forty years, your club needs your strong support... NOW! This is not just my usual plea for volunteers or participants at upcoming events, I'm talking about the on-going existence of this club. We are entering a critical transition as four Board members are not seeking re-election. If concerned members step up and fill those positions, we'll be fine. If not, this club will be in trouble. Six people can't do all the work. So here's what you have to do if you care about AROO.

First, give serious thought to running for the Board. If you are a long-term member and have never served on the Board, it's your turn. Even if you just joined us, we need all the skills, talent, and time you have to offer. This is no time to be standing around with your hands in your pockets, kicking the dirt, hoping someone else raises their hand. The Board runs the business of the club, sets the calendar, makes policy, crafts the budget, and otherwise makes things work. This is a volunteer organization and nothing gets done unless someone does it. And the Board is where most of that "doing" gets done. So, do it.

Second, vote in this year's election. We have right around 150 members and typically only 25 or 30 of you cast votes. The Board election is how members can influence the club's leadership and direction. Not voting says you don't care, and it's discouraging to work for and represent people who don't care. So cast your vote by mail or in person at the November meeting, but vote and show that you care about AROO. And tell your fellow club members to vote, too.

Third, once we have a new Board, lend a hand. Way too much is expected of Board members. While we are supposed to coordinate events, in past years we have become the only ones working on them. So give a Board member a break this year and volunteer to put on a tour, organize an event, or present a program at a meeting. They will need your help.

And here's more: our annual AROO Auction is at the November meeting, same night as the election. So in addition to bringing your ballot, bring some stuff to sell (Alfa related is nice, but not required) and some money to spend. The last couple of years we brought in enough to pay the rent on our meeting room for the whole year. Let's do it again.

That's about all I've got. We had a great President's Tour (see elsewhere for the story and photos) and we have the Volunteer Appreciation Dinner on October 18 and Track Day on the 24th. Here's a special deal: sign up to be a volunteer at Track Day and you can come to the Volunteer Dinner on the honor system. Just go to: <http://www.motorsportreg.com/> Search for AROO and sign up just like you were going to drive, but there is no charge for volunteers. I'll be out there and I hope to see you there supporting your club and having a good time.

**AROO BOARD OF DIRECTORS MEETING - MINUTES****Sept 2, 2015**

Location: Buster's BBQ. In Attendance: Roger, George, Russ, Cindy, Lee Anne, Bob, David, Mark, Neil. Absent: Yulia

**Time: 7 pm**

Upcoming events and Liaison reports

1. Minutes review – Russ Paine - Approved
2. Treasurer's Report - Cindy Banzer – discussed and no changes.
3. Past events reports:
  - a. AROO August Evening Tour – 5 cars, 14 people, dinner very good at Bocchi's
4. Upcoming events
  - a. Sept 16: AROO Membership Meeting – Yulia and activity photo display
  - b. Sept 19-20 AROO Fall Tour to Astoria
  - c. Sept 27 Fifth Annual President's Tour – Roger – half day in Washington location
5. MSNCR 2016 report – Jim/Mark – 69 entrants, committee forming. Recruiting Rallymaster and Treasurer.
6. Calendar Review – Bob – discussion of website hosting and calendar maintenance.
7. Membership Report – Yulia – absent. Lee Anne will try to determine new 2015 members. Target is to have full list for October newsletter.
8. Merchandise/Apparel - Lee Anne – no changes.
9. Competition and track – Mark and Neil “Are we going to be operating on the old AROO rules or the AROC National rules?  
If we're going to run under the AROC National rules, what's the plan for getting the news out to our customers? We don't want to get caught having customers show up with cars that meet our obsolete AROO rules and turn them away (without refund?) because they don't conform to the AROC National rules. Roll bars for open cars is one area where the rules differ significantly. I've taken it on myself to convey the probable roll bar changes to Patrick Iaboni and Terry Frederickson (AROO members who run open cars) but we owe it to the rest of the customer base to get the news out.” (by Bob Stewart)  
\*Discussed Tech: Objective is safety. New helmet and rollbar requirements to be added to MotorSport.reg. Will sticker approved helmets.  
\*Discussed price structure: \$150 Oct 12, \$194 Oct 19<sup>th</sup>, \$240 day before, \$260 day of. Neil lobbied for a reduced \$90 rate for instructors – Neil to review and approve them. Motion approved. Eblast to promote and will include links to YouTube Track Day videos.
10. Advertising/Promotion/ Bits – George
  1. AROC report – Cindy –national website in works, getting close. Promotion of NW Classic on national level planned.

New and Continuing Business

1. Alan Chockie needs to be replaced as web site developer. Doug Zaitz volunteered, any other options to consider? Action – Cindy will contact Doug
2. AROO Christmas Party (and Volunteer Appreciation Party) budget adjustment - \$1800, motion approved. Cindy will contact MAC Club to secure date.
3. Begin thinking about the 2015 Rally windfall and how best to use it. – no discussion.

Adjourned 9:10 pm,

**Submitted by Russ Paine, Secretary**

RESTORATION | PRESERVATION | SERVICE



# SPORTS CAR SHOP

RESTORATIONS

BY JOSEPH POTTER

WEST COAST PICK UP AND DELIVERY | 541.510.5296  
[SPORTSCARSHOP.COM/RESTORATIONS](http://SPORTSCARSHOP.COM/RESTORATIONS)

## **AROO Needs You!**

### **Five Positions Open on the AROO Board of Directors**

**Applications due by  
Wednesday, November 4, 2015, 5:00 PM**

AROO members are eligible to serve on the AROO Board of Directors. Ten members comprise the Board; five members are elected each year.

As well as determining policy to fulfill AROO goals and organizational obligations, responsibilities of Board members include: participation in monthly meetings; participation in club business discussions and votes on motions; and coordination of a specific task or event. Further, each Board member hosts one monthly General Membership meeting. Board members elect the President, Vice President, Secretary and Treasurer.

Board members, elected at the November General Membership Meeting, serve a two-year term, beginning with the December Board meeting, held the first Wednesday of the month.

Applications may be submitted by mail or email no later than 5:00 pm on Wednesday, November 4, 2015, to AROO Treasurer Cindy Banzer at [cbanzer@eastpdxproperties.com](mailto:cbanzer@eastpdxproperties.com); 6505 SE Stark St, Portland, OR 97215, ph) 503 709 7277.

The AROO Board has reinstated the Vote By Mail procedure. All AROO members will receive a ballot to be returned by mail or in person at the Wednesday, November 18, 2015, General Membership Meeting. Ballots will be mailed after the filing deadline.

For more information on the process, kindly call or email AROO Treasurer Cindy Banzer.

Please join us for the  
AROO General Meeting at  
Ernesto's Italian Restaurant,  
8544 SW Apple Way, Portland, OR 97225.

**October 21st at 7:30 pm.**

George Kraus will present a slide show chronicling the 14 month, 6 hr. a day, 6 days a week restoration of his 1960 Giulietta Spider Veloce. Also included in the presentation are photos of his vintage British motorcycle restoration work.

And much, much, more...



## McGirr's Fall Tour to Astoria *By George Kraus*

If you missed this year's fall tour organized and led by Tom McGirr, then you missed a really great tour. The weather was wonderful to start, warm and sunny, and ended dry as well.

The tour led us over wonderful backroads to Gaston and Carlton with a rest stop at Lower Wennerberg Park. We continued on small traffic free single-lane logging roads and country back lanes; eventually making our way to US101 on the coast. We all enjoyed a nice lunch at the Grateful Bread Bakery — arriving in two shifts — the more spirited drivers at the front. The baked goods were divine.

After lunch we made our way to Astoria, a good part of the driving on 17 miles of the notoriously twisty Hwy. 53. Wahoo!

Most of the group stayed overnight in Astoria and dined at the Bridgewater Bistro. I, on the other hand, joined my friend Tom Franco and friends at the Buoy Brewpub. Tom was leading the MG club on a separate tour and also ended up in Astoria.

Sunday morning brought drizzle and overcast. Typical Astoria weather. Tops up to start we made our way east on Hwy, 202, Scappoose Vernonia Hwy, and the Lower Columbia Hwy. We all enjoyed a lovely lunch at the restored Rock Creek Tavern. From there we all made our separate ways home.

Thank you Tom for a delightful tour.



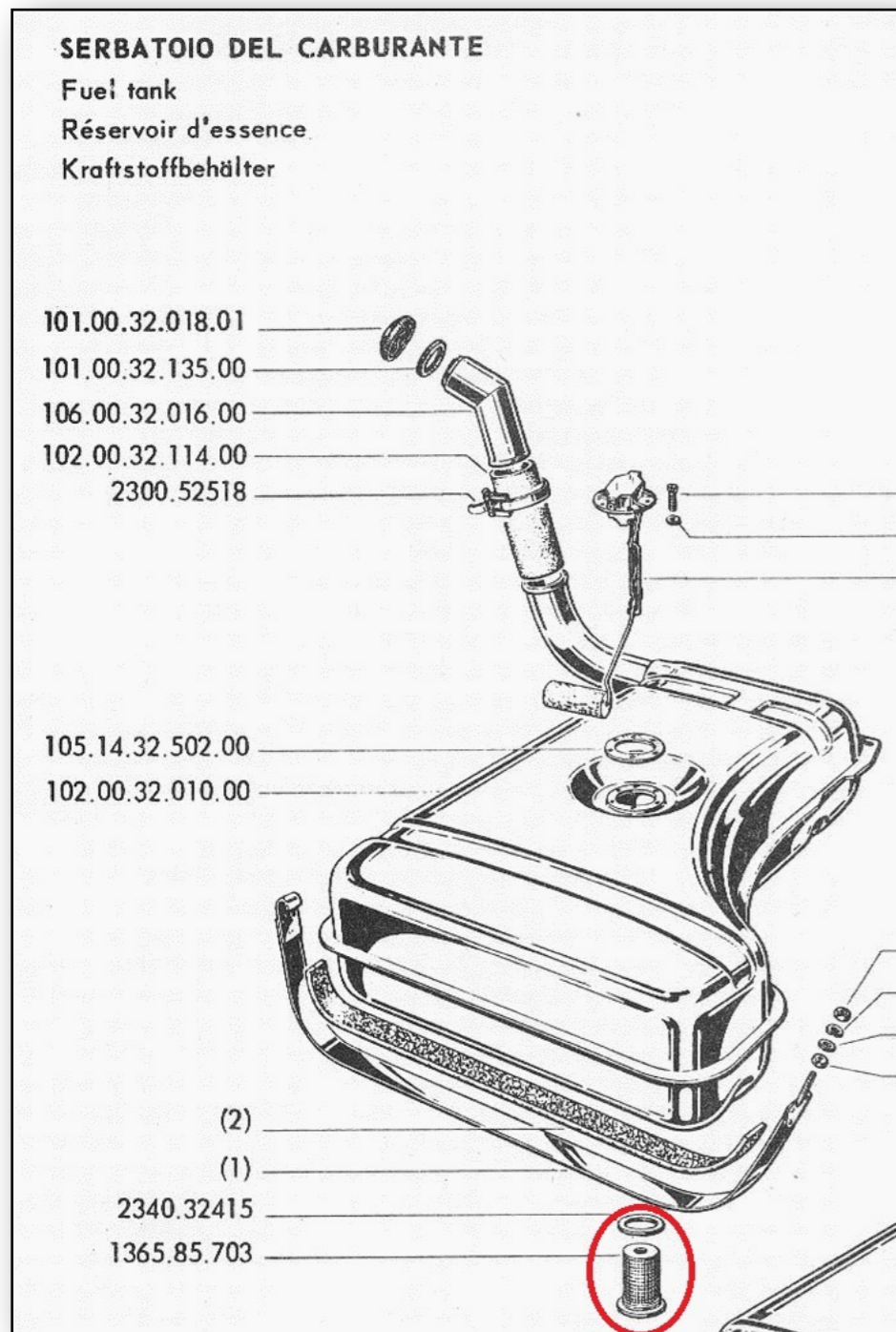

## 750/101 Fuel tank Filter Cleaning

By Al Rossman/Dave Beach

Perhaps your ol' sprint or spider isn't what it used to be . You've tuned it, electrified it, carbureted it, and it still doesn't go. Perhaps you've overlooked the always fun to clean tank fuel filter. What makes it fun is that it's **INSIDE** the tank. This past weekend, we pulled the filter out; you'll need a 17mm allen wrench and maybe a cheater to help free it if it's not been done in recent memory...or ever. The filter is a nice piece of work; brass mesh surrounding a metal frame; with an o-ring gasket set in top end thru which the fuel intake pipe passes. A vertical sheetmetal cylinder, about 1 inch larger diameter than the filter, and somewhat taller, is spot welded inside the tank; it's purpose is to prevent fuel sloshing from destroying the filter in those 1.5-G corners..or other Rally surprises. The bottom of this cylinder has two 1/8inch diameter holes, one front, one aft, which allow fuel access to the filter when fuel level drops below the top of the spot-welded cylinder.

We found the two holes plugged with sand and rust. Apparently someone tried to run the car on sand and water in the past, because the cylinder was half full of sand and rust. The filter brass mesh had several holes, which we repaired with J-B-Weld, after soaking the **TOTALLY** varnish-plugged filter in carburetor cleaner for 2 hours. Obviously the only fuel (and sand and rust) passing thru the filter was thru the holes in the filter. The fuel pump seems to have miraculously survived this punishment, as the little 1600 ripped right along during a subsequent test drive.

Well worth the effort!!

Keith first joined the Alfa Romeo Owners of Oregon club in 1969

# Keith Martin's Sports Car Market™

The Insider's Guide to Collecting, Investing, Values, and Trends

"I love Sports Car Market. Somehow in my busy lifestyle I find time to read every issue. Congratulations on 27 years." — Brad B., Houston, TX

## Subscribe Today!

Get 12 issues of Sports Car Market at a special AROO member rate, plus SCM ball cap and lapel pin.



## 877.219.2605 Ext. 1

[www.sportscarmarket.com/AROO](http://www.sportscarmarket.com/AROO)

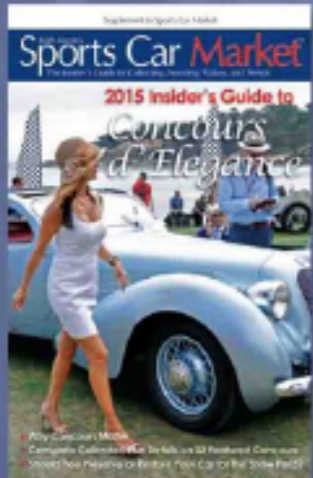

SPECIALIZING IN PROPERTIES  
WITH LARGE GARAGES

CINDY BANZER, PRINCIPAL BROKER

M) 503 709-7277

CBANZER@EASTPDXPROPERTIES.COM



Windermere/Cronin & Caplan  
Realty Group, Inc.



### NASKO'S IMPORTS & PORTLAND MINI



With over 30 years in business we are Portland's oldest independent Alfa Romeo facility.

**We are:**

- Dedicated to preventative maintenance for your Alfa Romeo.
- Attentive to customers individual needs.
- A conscientious repair staff with diverse Alfa Romeo know-how.
- Our reputation is built on these things and we thank our local customers whose continued support and referrals have helped us continue doing business this way.

**We Offer:**

- Service - Alfa Romeo as well as other fine European automobiles.
- Parts - Large stock of new and used.
- Sales - Used European automobiles.

**NASKO'S IMPORTS/PORTLAND MINI**

5909 S.E. Francis (54th & Foster)  
Portland, OR 97206 • 503 771-1472

## EVERY FIRST WEDNESDAY:

Board Meeting at Buster's Barbecue in Tigard at 7 PM.

## THIRD WEDNESDAY OF EACH MONTH:

Monthly Meeting at Ernesto's 7:30 PM — September through June. Evening tours — July and August. Check the complete AROO calendar [HERE](#).

## Save The Dates!

### AROO HOLIDAY PARTY

Sunday, December 6, 2015, Multnomah Athletic Club

Details: Page 18.

.....

AROO VOLUNTEER APPRECIATION DINNER.

Details: Page 17.

## Here are some videos of AROO "Track" days at PIR!

**Any Experience Level:** <https://www.youtube.com/watch?v=lk4vtwGtSAk>

**Any Age:** <https://www.youtube.com/watch?v=CYvCdMMc4WU>

**Any Car:** <https://www.youtube.com/watch?v=PRJKtO67utM>

[Click HERE to see all AROO activities.](#)

## October

3 Concours de Maryhill.

7 Board Meeting, Buster's Barbecue, 7 PM Tigard.

18 AROO Volunteer Appreciation dinner ([See page 17](#)).

21 AROO monthly meeting at Ernesto's 7:30 PM.

24 AROO Track day PIR ([See page 20](#)).

## November

4 Board Meeting, Buster's Barbecue, 7 PM Tigard.

18 AROO monthly meeting at Ernesto's 7:30 PM.

## December

2 Board Meeting, Buster's Barbecue, 7 PM Tigard.

6 AROO Holiday Dinner ([See page 18](#)).



## THE MONTE SHELTON NORTHWEST CLASSIC RALLY XXVIII PRESENTED BY THE ALFA ROMEO OWNERS OF OREGON

July 28-31, 2016

October 8, 2015

### Greetings AROO members

It is time to get the 2016 rally organized. In doing so we will be forming a group of volunteers to help guide the event as well as perform the jobs needed to make this rally successful. Mark and I are excited at the positive response received from the entrants and sponsors as well as those club members that have helped in the past.

If there is something you might offer that would continue to make this a special function for automobile enthusiasts we would like to hear from you. From food planners to checkpoint workers as well as registration and greeting personnel we can probably use your skills this year.

If this interests you please e-mail Mark Carpenter at [greyalfa@hotmail.com](mailto:greyalfa@hotmail.com) or Jim Gunter at [nwrally@comcast.net](mailto:nwrally@comcast.net). I can also be reached at 503-701-2980. We appreciate the opportunity to re-join this successful venue and look forward to hearing from others that feel the same. Thanks for your consideration.

*Jim Gunter*

Photos George Kraus  
2015 Northwest Classic Rally



Please consider these rally sponsors when you need any of these services.

## **TITLE SPONSOR**

Monte Shelton Motor Company

## **DIAMOND SPONSOR**

Anonymous

## **PLATINUM SPONSOR**

Adjusters International

ARCIFORM

Columbia Roofing & Sheet Metal

Ivey, Jacobson & Co.

Landscape East & West

Maynard Chambers

Kelley's Olympian

Provenance Hotels

Speed Sports

## **GOLD SPONSOR**

Arrow Mechanical

Barn Finds

Bring a Trailer

Cascade Investment Advisors

Guy's Interior Restorations

Hagerty Collector Car Insurance

Harold's Auto Service

Income Property Management

Keith Martin's

Sports Car Market Magazine

Minute Man Press — Lloyd Center

Pacific Real Estate Investments

Scooter Gabel

Scott Lowman

Sidedraught City

Sports Car Shop

Tom's Jaw Shop

Touring Club of Oregon

Uptown Auto Detail

Windermere Realty Group



---

---

**HAGERTY**®

---

---

**PROUD TO SUPPORT**

---

---

**THE ALFA ROMEO OWNERS OF OREGON**

---

---

CLASSIC CAR INSURANCE | 800-922-4050 | HAGERTY.COM

# ARROW

MECHANICAL CONTRACTORS INC.

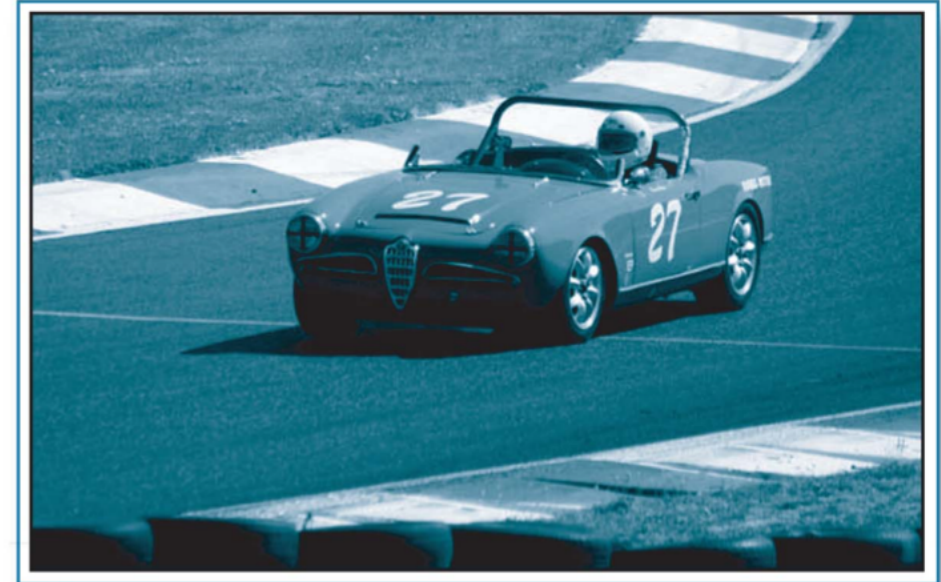

## *Proven Winners*

- HEATING AND AIR CONDITIONING CONTRACTORS
- SYSTEMS DESIGN AND INSTALLATION
- SERVICE, REPAIR, AND UPDATING OF SYSTEMS
- PREPLANNED PREVENTATIVE MAINTENANCE
- RESIDENTIAL AND COMMERCIAL



Turn to the Experts™

**503-692-1565**

**DO ANY OF THESE SOUND FAMILIAR?**

- Frustrated by repeated leak calls for the same leak?
- Annoyed by roofing contractors lack of communication?
- Scared that roofing contractors don't warranty or stand behind their work?



*When you're ready to solve these types of issues, call Columbia Roofing & Sheet Metal — the commercial roofing specialists.*

**COLUMBIA**  
**ROOFING & SHEET METAL**

**503-684-9123**  
**reroofnow.com**

*Practicing the art of investing for you.  
Specializing in value investing  
for individuals*

Cascade Investment Advisors, Inc. was formed in 1997 for the benefit of investors who seek customized, individual asset management at reasonable fees. The firm specializes in individual security selection with a value orientation: we shop the markets for the best values in assets.



*Cascade Investment Advisors, Inc.*

Get in touch with us

503 High Street • Oregon City, OR 97045  
503-417-1950 • 888-443-9015

[www.cascadeinvestors.com](http://www.cascadeinvestors.com)





# ADVERTISERS

Please note that your ads may now be presented in full color. Please take advantage of this feature to make your ads even more appealing.

### Annual rate\*

**Full-page** 10" w X 7.5" h \$250; **Half page** 4.75" w X 7.5" h \$150; **Quarter page** 4.75" w X 3.5" h \$100; **Business Card** 3.5" w X 2" h \$50.

\*When you buy a full -page ad for a year, we also place your link and/or banner on our website.

Contact the Advertising Manager George Kraus for more information.

## PMX Custom Alternators & Starters

Quality Rebuilding Since 1977 • Foreign & Domestic

**Alternators:** Chrome, One Wire, 6 Volt, Positive Ground, Custom High Amp, Marine, Kits to Convert from Generator to Alternator for Most Systems including Flathead V-8 and Model A's.

**Starters:** Chrome, Hi-Torque, Convert 6 Volt to 12 Volt, Gear Reduction Starters for Big Block Ford and GMs.

PMX, Inc.  
8420 S.E. Hinckley  
Happy Valley, OR 97086

Bill Jungck  
(503) 777-7172  
FAX: (503) 777-7156  
www.pmxalternators.com

THE FINEST UPHOLSTERY FOR YOUR CAR

**GUY'S** INTERIOR RESTORATIONS

AWARD WINNING INTERIOR RESTORATION

**FULL SERVICE AUTO UPHOLSTERY**

**ORIGINAL & CUSTOM INTERIORS**  
Sports, Luxury, Exotics, & Classics - Foreign & Domestic

Guy Recordon  
Jim Enger  
2016 NE Alberta  
Portland OR 97211

**CONVERTIBLE TOPS**  
A Specialty

**LEATHER RESTORATION**  
Dyeing & Color Matching

**503 224-8657**



Neil d'Autremont  
503 548-6334

9125 SE 64th Ave  
Suite 1  
Portland OR 97206

**NEW LOCATION!**



sidedraughtcity.com

## Buster's Texas Style Barbecue

11419 SW Pacific Hwy

Tigard, OR 97223

7 p.m.



## All AROO VOLUNTEERS - we want to take you to dinner!!

Please be our guests at the annual Volunteer Dinner, Oct 18 at Ernesto's Italian Restaurant, 6 p.m., 8544 SW Apple Way, Portland Or 97225. The help you volunteers give us year round is greatly appreciated, and this is our small way of thanking you.

“ We couldn't do all the great AROO events without you! ”

Please RSVP at your earliest convenience, but **no later** then Oct 13th to Lee Anne Barham, 503-484-8950 or [leeanne.barham@gmail.com](mailto:leeanne.barham@gmail.com).

**After Oct 13**, please contact Bob Stewart at [Bob.Stewart@AlfaClub.org](mailto:Bob.Stewart@AlfaClub.org) to see if space is available.



Please join us to celebrate a great year for AROO at the

# Annual Holiday Party,

Sunday, December 6 2015, at the Multnomah Athletic Club

No-host cocktails 5:30 – 6:30 p.m., dinner 6:30 – 9:30 p.m.

Dinner is \$38 per person, all inclusive with gratuity and parking\*  
House wine is \$22/bottle, or bring your own – corkage fee is \$15.

Please mail checks payable to AROO by November 30th to  
Cindy Banzer, 6506 SE Stark St., Portland OR 97215.

(Your check is your reservation.)

The Multnomah Athletic Club is located in downtown Portland at  
1849 SW Salmon Street. Click [HERE](#) for map.

*\*Included parking is available in the MAC parking garage across Salmon Street  
from the main entrance.*

.....  
For more information contact Cindy Banzer: [Cindy.Banzer@alfaclub.org](mailto:Cindy.Banzer@alfaclub.org) or 503-709-7277.



## Fifth Annual AROO President's Tour a Big Success

by Roger Dilts

Nearly 40 members and friends of AROO gathered on the first Sunday morning of autumn in the Columbia Gorge, ready to head into the Gifford Pinchot National Forest on the fifth annual AROO President's Tour. Connie and I braved the drive out to the start with the top down. Dang, it was cold and our fingers got pretty stiff, but we arrived with smiles and coffee and cookies for all, so we got a warm welcome. There was a great mix of cars, including several spiders, a couple of Supers, a Sprint, a GTV and GT Jr, plus a Morgan, a Jaguar Mk II, and VW GTI. As soon as everyone got signed in, we lined up in two groups and headed north along the Wind River Highway. The fall colors were just coming out – bright yellow big leaf maples and crimson vine maples lined the road and filtered the morning light.



After a fairly straight run past the town of Carson, we began a stunning climb up through the forest on Oldman Pass. The road is recently paved so the surface is perfect and the turns as sweet and crisp as a fall apple. Once over the top, we took our first break at the McClennan Overlook and were treated to a rare cloudless view of Mt. St. Helens. A few miles further on, the quality of the road dropped considerably and few short unpaved sections and pavement slumps kept speeds slow and eyes out for potholes. Once through that, we took a nice long break at the Lower Falls Recreation Area on the Lewis River. A short walk through the mossy woods took us to an overlook with stunning views of the falls. After we'd had enough splendor, we piled back into the cars and continued the tour.

The road continued rather rough, although the more leisurely speeds encouraged sightseeing, at least by navigators. Drivers had to keep a sharp eye out. Here the cliffs are close in and verdant with moss and ferns and we catch quick glimpses of whitewater as the road crosses tumbling mountain streams. After another nasty patch of road, things improved quite nicely for a long, sweeping descent through the forest to the town of Trout Lake and down the beautiful White Salmon River valley to end the tour with lunch at Everybody's Brewing.



I started the AROO President's Tour five years ago as a way to share with my friends some of the roads I'd found doing rally recon. We've gone to some great places together and I've really enjoyed it. Thanks to all who've come along over the years. As my time as president ends, I hope I've started a tradition that will be continued by the next AROO president, whoever that may be.

## AROO TRACK DAY at PIR

AROO track day is rapidly approaching and registration is open September 12, 2015, 12:00 AM PDT. Come join us for our October Track day at Portland International Raceway, Saturday October 24th.

- **Drivers Registration:** Please click [here](#) to register.
- **We need volunteers!** If you are interested in volunteering please click [here](#) for volunteer registration.

Here are some videos of a previous track day this year. Enjoy!

Any Experience Level: <https://www.youtube.com/watch?v=lk4vtwGtSAk>

Any Age: <https://www.youtube.com/watch?v=CYvCdMMc4WU>

Any Car: <https://www.youtube.com/watch?v=PRJKtO67utM>

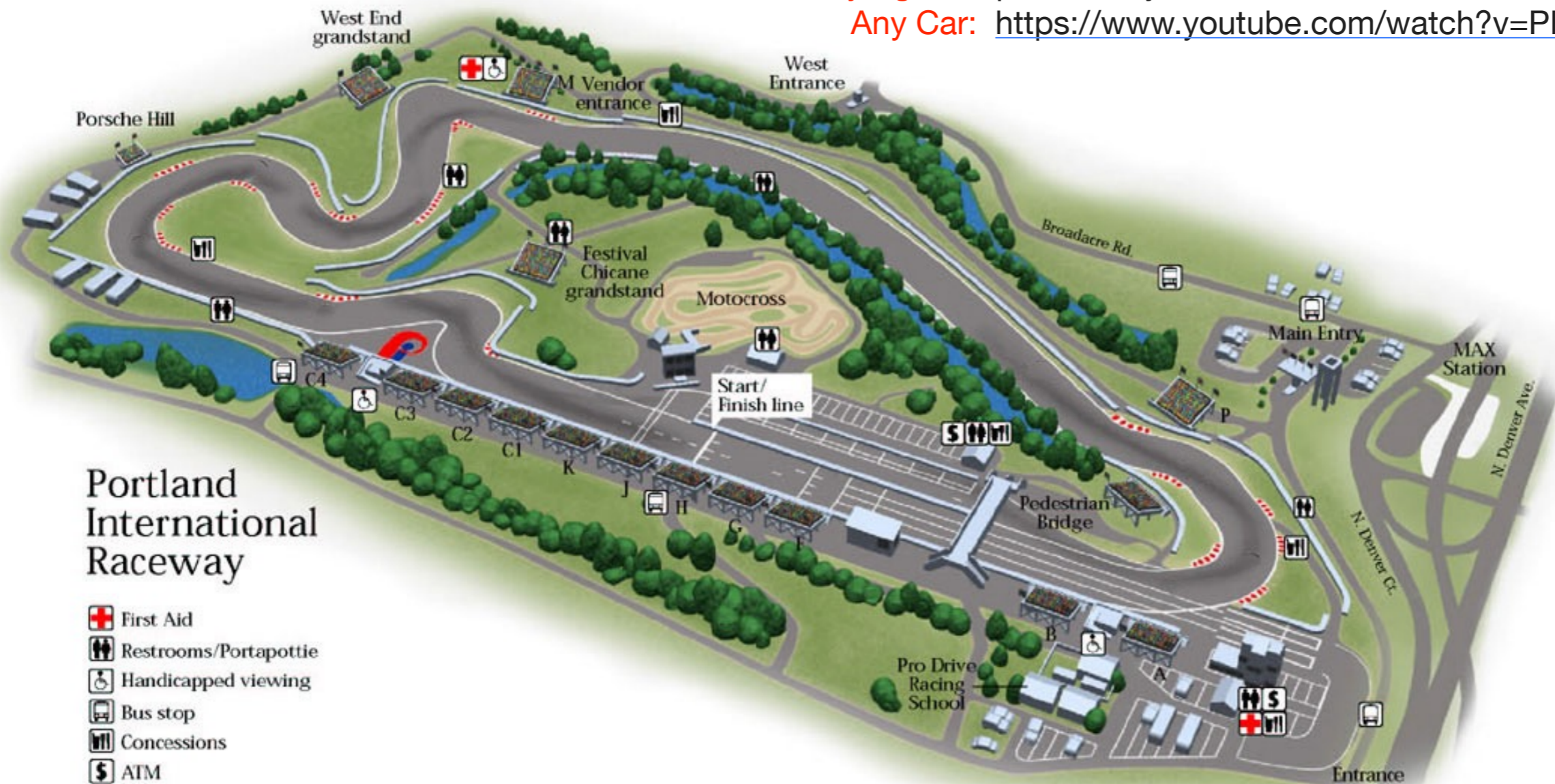

# The Back Seat



Photo George Kraus  
Tom McGirr's Astoria Tour 2015